

harmon/kardon

speaker control redesign

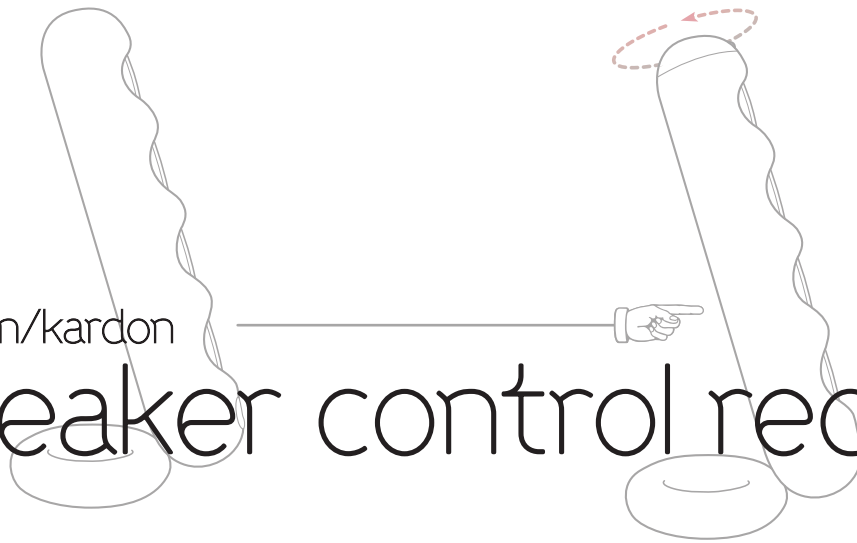

current state

two touch sensitive pads. touch right pad to increase volume.
touch left pad to decrease volume. press both to mute.

drawbacks

pads provide no feedback. touch sensitive nature provides no way to easily control volume level.
two-button mute not intuitive. two-button mute necessary as easily returning to a previous volume is not possible.

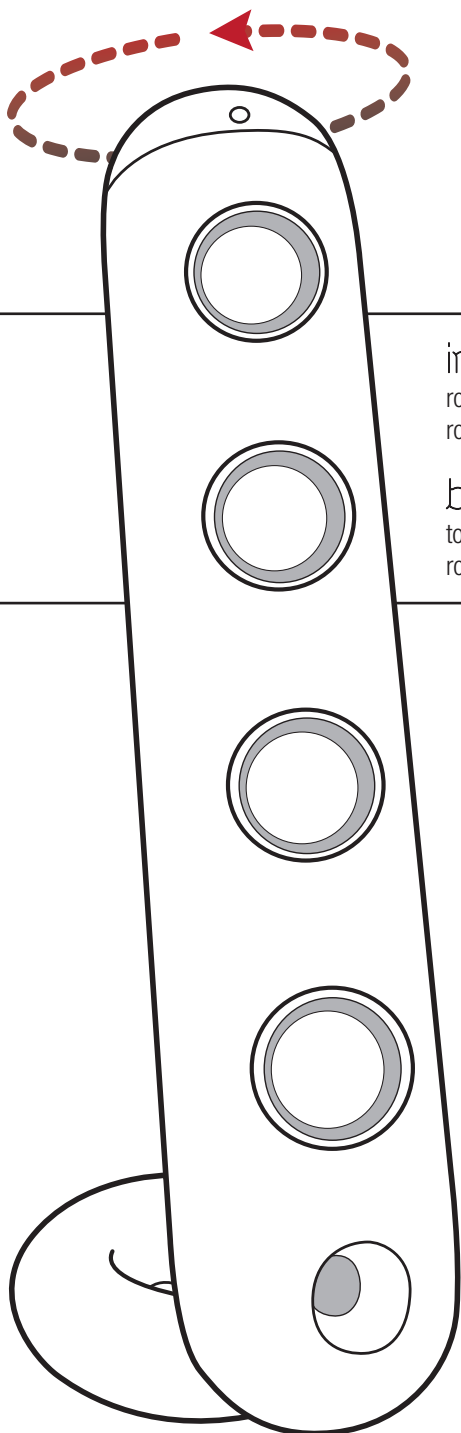
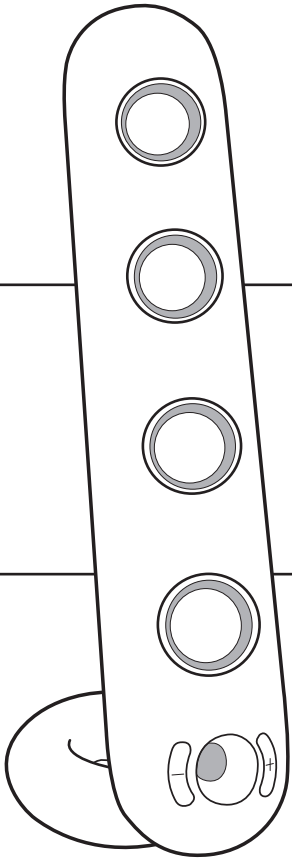

improved state

rotating knob with centering touch-point. rotate clockwise to increase volume.
rotate counter-clockwise to decrease volume. turn knob all the way counter-clockwise and feel a tangible click to turn off.

benefits

touch-point shows current volume level and provides means for accurately returning to previous volume level.
rotating for volume is intuitive. turning music all the way off obviates need for a mute function.

